

OVERHAUL OF B4 AND B5 BOGIES

C.E.P.S. 1067

CONTENTS:

1. INTRODUCTION
2. GENERAL NOTES
3. BOGIE TYPES
4. GLOSSARY OF TERMS
5. LUBRICATION SCHEDULE
6. INDEX TO ENGINEERING INSTRUCTIONS
7. INDEX TO DRAWINGS
8. DISMANTLING
9. LIST OF COMPONENTS

10. OVERHAUL OF COMPONENTS
 - 10.1 Axle Bearing
 - 10.2 Axlebox Casting
 - 10.3 Axlebox Guide and Dashpot
 - 10.4 Bogie Frame
 - 10.5 Bolster
 - 10.6 Bolster Control Arm
 - 10.7 Brake Block
 - 10.8 Brake Disc
 - 10.9 Brake Gear (Rigging)
 - 10.10 Brake Gear Safety Hanger
 - 10.11 Lateral Bump Stop
 - 10.12 Bow Girder
 - 10.13 Centre Bearing
 - 10.14 Earth Strap
 - 10.15 Friction Damper
 - 10.16 Hydraulic Damper
 - 10.17 Lateral Tie Rod
 - 10.18 Primary and Secondary Coil Springs
 - 10.19 Secondary Suspension Bolt and Rocking Washers
 - 10.20 Spring Plank
 - 10.21 Spring Plank Safety Loops
 - 10.22 Wheels and Axle Including Alternator/Generator Pulley
11. ASSEMBLY
 - 11.1 General
 - 11.2 Secondary Suspension
 - 11.3 Wheelsets and Primary Suspension
 - 11.4 Brake Gear (Rigging)
 - 11.5 Bogie Regulation
12. APPENDICES

1. INTRODUCTION

- 1.1 The information contained in this document relates to the workshop overhaul of B4 and B5 bogies removed from vehicles undergoing main works repair and returned to main works from regional maintenance depots. These instructions, together with all instructions, specifications and other publications issued by the DIRECTOR OF MECHANICAL & ELECTRICAL ENGINEERING must be complied with.
 - 1.2 This document does not refer to the overhaul of any electrical components attached to the bogie.
 - 1.3 The sizes and tolerance of components manufactured to imperial dimensions and quoted in this document as originally specified and should be measured as such. Wear tolerances for these components are also in imperial sizes. Metric sizes are only quoted where they are called for on the relevant drawing(s).
-

2. GENERAL NOTES

- 2.1 The condition of all components and systems on completion of repairs must be such that the safety of the public and staff alike is not in any way endangered. If any doubt exists remedial action must be taken.
- 2.2 The contractor will be responsible at all times for the implementation of all relevant codes of practice and safety regulations.
- 2.3 Temporary repairs and other work of an unofficial nature undertaken by depot staff must be detailed on Shopping Proposal Forms and rectified and/or removed unless otherwise directed by the regional RM & EE or the D of M & EE's Quality Assurance Engineer.
- 2.4 Non-destructive testing must be carried out in accordance with the relevant Engineering Instruction.
- ~~2.5 This specification applies to all relevant components where there are more than one on a bogie.~~
- 2.6 On completion the bogie must be painted in accordance with the Painting Schedule BR2.
- 2.7 It is the responsibility of the contractor to ensure that all repaired components and systems conform to the current D of M & EE's standards and that the current issue of all instructions and standing orders are complied with.
- 2.8 Materials used in repairs should be to the D of M & EE's authorised specifications but if not available, or a change is desirable, then the approval of the D of M & EE's Quality Assurance Engineer must be obtained.
- 2.9 The Contractor must notify the D of M & EE's Quality Assurance Engineer of any desire for the work being undertaken to differ from the standards laid down by the D of M & EE and obtain prior approval.
- 2.10 All bogies after completion, and before release to the regional RM & EE, must be inspected to ensure that the repair conforms to the standards laid down by the D of M & EE.

3. BOGIE TYPES

<u>Bogie</u>		<u>Vehicles Fitted</u>
B4 Mk II	Flat belt drive generator pulley	
B4 Mk III	Flat belt drive generator pulley	
B4 Mk III	Flat belt drive and bogie mounted alternator	
B4 Mk IV	Vee belt drive and bogie mounted alternator	Mk II
B4 Mk V	Flat belt drive generator pulley	Mk I
B4 Mk VI	Flat belt drive generator pulley	Mk I
B4 Mk VII	Vee belt drive and mounted alternator	Mk II
B5 Mk II	Vee belt drive and bogie mounted alternator	Mk II
B5 Mk III	Flat belt drive generator pulley	Mk I
B5 Mk IV	Flat belt drive generator pulley	Mk I
B5 Mk V	Vee belt drive and bogie mounted alternator	Mk II

4. GLOSSARY OF TERMS

<u>Term</u>	<u>Action Required</u>
CHANGE	Remove the original and fit a new or overhauled part or assembly in its place.
CHECK	Determine a particular nominated condition before, during or after repair, eg. completeness, security, position.
CLEAN	Take off all dirt and deposits.
DISMANTLE	Take to pieces.
EXAMINE	Determine general condition before repair, eg. wear, cracks, splits, leaks, scoring, corrosion, breaks, distortion, looseness.
INSPECT	Determine general condition after repair and attention, ie. conformity to required standards.
OVERHAUL	Do what is necessary to make assembly or sub-assembly re-usable, ie. dismantle, strip, clean, examine, fit new parts, repair, re-assemble, test and inspect as required.
REASSEMBLE	Put together.
RECORD	Put down in writing a finding from examination, test, inspection or special checks.
RECTIFY	To set right.
REFIT	Put back and re-connect.
REMOVE	Disconnect and take off.
RENEW	Remove and scrap the original part and put new part in its place.
REPAIR	Restore an original part of the required condition by hand-tooling, machining, building-up, welding, patching, bending, setting, heat-treating, re-securing, etc.
STRIP	Take off covering, ie. paint, polish, fabric, etc.
TEST	Prove correct operation by trial.

(Based on Engineering Instruction G/82)

5. LUBRICATION SCHEDULE

<u>Component</u>	<u>Lubricant</u>	<u>BR Cat No.</u>
Brake Rigging	Grease	27/1361
Handbrake Mechanism	Grease	27/1361
Axle	Grease	27/1350
Axle Box and Bearing	Grease	27/1350
Spring Plate - Bolster Tie	Grease	27/1350
Control Arm Spigots	Copalsip	27/2437
Centre Pin	Grease	27/1350
Swing Link	Grease	27/1350
Secondary Dampers	Grease	27/4597
Primary Suspension Dashpots	Oil	27/12950

Note: Friction dampers, alternator mounting bushes, swing link, rocking washer faces and centre bearing friction pads must not be lubricated.

6. INDEX TO ENGINEERING INSTRUCTIONS

- G/10 Standard Instruction for Ultrasonic Testing of Axles.
- G/11 Wheels with Balance Plates to Drg. No. B-AO-986.
- G/56 Protective Coating for Stem Ends on Hydraulic Dampers.
- G/59 Priming of all Lateral Hydraulic Dampers with Reservoir Domes.
- G/61 Control of Welding Standards.
- G/63 Roller Bearing Axle Boxes : Securing of Front Cover.
- G/66 Reaming of Loop Ends of Hydraulic Dampers.
- G/81 Tyre Tread Surface Texture.
- G/82 Definition of Terms (see Section 4).
- ~~G/85 Replacement of Covers for Existing SKF Roller Bearing Axle Boxes.~~
- G/171 Condition of Wheel Mounted Cheek Discs.
- G/188 Hydraulic Dampers - Definition of Leakage.
- G/254 Axlebox Roller Bearings - Identification and Reporting of Defects and Failure. Acceptance Standards for Re-use.
- G/269 Improvement of Axle Geometry and Reclamation of Trailing Axles.
- G/281 Reclamation of Traction Rods with Worn Bush Housing.
- G/354 Standardisation of Tyre Machining Details.
- G/360 Reclamation of Scored Axles on Trailing Wheelsets.
- G/396 Rationalised Brakeblocks.
- G/497 Standardisation of Wheel Back to Back Dimension.
- G/498 Axle attention required to eliminate intrusive signals during ultrasonic examination.
- HC/18 Vee Belt Pulley Wear. Examination and Corrective Action.
- HC/80 Fitting of BR C2A Brake Blocks.
- HC/89 Primary Suspension - Friction Damper.
- HC/258 Axle journal corrosion: Detection, Treatment and Examination for Cracks, S.K.F. Roller Bearing Axleboxes.
- HC/455 Attention required to wheel centres.

It is the responsibility of the Contractor to ensure that the current issue of the instructions listed above and of all other relevant standing instructions and orders are complied with.

7. INDEX TO DRAWINGS

<u>Bogie</u>	<u>General Arrangement</u>	<u>Brake Arrangement</u>
B4 Mk II	SC/SW/183	SC/SW/145
B4 Mk III	SC/SW/139 & 182	SC/SW/145
B4 Mk IV	SC/SW/3193 & 3194	SC/SW/3158
B4 Mk V	SC/SW/3348 & 3349	SC/SW/3350
B4 Mk VI	SC/SW/4184	SC/SW/4186
B4 Mk VII	SC/SW/4220 & 4221	SC/SW/4215
B5 Mk II	SC/SW/3178 & 3187	SC/SW/3158
B5 Mk III	SC/SW/3346 & 3347	SC/SW/3350
B5 Mk IV	SC/SW/4185	SC/SW/4186
B5 Mk V	SC/SW/4222 & 4223	SC/SW/4215

8. DISMANTLING

- 8.1 Remove alternator (where fitted), brake gear, secondary suspension, wheelsets and all associated components. Clean bogie frame and all components so that accumulations of dirt, oil and grease, and all loose paint is removed.
 - 8.2 Record bogie and wheelsets serial numbers.
-

9. LIST OF COMPONENTS

The numbers shown against each item listed below may be used as reference for Section 10 'Overhaul of Components'.

1. Axlebox Bearing.
 2. Axlebox Casting.
 3. Axlebox Guide and Dashpot.
 4. Bogie Frame.
 5. Bolster.
 6. Bolster Control Arm.
 7. Brake Block.
 8. Brake Disc.
-
9. Brake Gear (rigging).
 10. Brake Gear Safety Hanger.
 11. Lateral Bump Stop.
 12. Bow Girder.
 13. Centre Bearing.
 14. Earth Bonding Strap.
 15. Friction Damper.
 16. Hydraulic Damper.
 17. Lateral Tie Rod.
 18. Primary and Secondary Coil Springs.
 19. Secondary Suspension Bolt and Rocking Washers.
 20. Spring Plank.
 21. Spring Plank Safety Loops.
 22. Wheels and Axle Including Alternator/Generator Pulley.
 23. Pull Rod.

10. OVERHAUL OF COMPONENTS

10.1 Axlebox Bearing

- 10.1.1 Clean, examine and regrease SKF spherical roller bearings in accordance with C.E.P.S. 1002, section A, paragraphs 2.1.1 to 2.1.4 inclusive.
- 10.1.2 Clean, examine and regrease Timken SP cartridge tapered roller bearings in accordance with C.E.P.S. 1017, section A, paragraphs 1.2 to 1.2.4 inclusive.

E.I.'s G63 and G85 must also be observed.

10.2 Axlebox Casting

- 10.2.1 Visually examine axlebox castings for cracks or damage.
- 10.2.2 Clean spring seat areas of all loose scale and deposits of dirt.
- ~~10.2.3 Check security of primary damper friction links, (which should return to vertical position when displaced). If a securing bolt is loose remove the link and gauge the axlebox lug bushes for wear, renewing if worn in excess of 1/32"; renew bolt.~~

If excessible link movement is apparent indicating a perished rubber mounting, renew the defective item.

- 10.2.4 Examine primary damper friction link slots for wear and rectify if in excess of 1/16" on either side.
- 10.2.5 Examine earth bond location threads and re-tap if necessary.
- 10.2.6 Clean interior of bearing housings prior to reassembly with roller bearing units.

10.3 Axlebox Guide and Dashpot

- 10.3.1 Drain the oil and dismantle and clean all of the components.
- 10.3.2 Examine the guide post for wear as follows:-

Main seal upper collar seat O.D.	4.621" min
Bronze bush seat O.D.	4.371" min

Ensure that the damper plate thread is clean and free running and that the four main seal lubrication holes are clear. Renew guide posts as necessary, for procedure see para 10.3.4.

- 10.3.3 Ensure that the guide posts are securely fastened to the bogie. If any fastening is loose it must be removed and if the hole is worn then the guide post should be renewed, for procedure see para 10.3.4. Otherwise the guide post should be correctly located using the longitudinal, transverse and diagonal gauges, Item Nos. 1/2/3 on Drg. No. SC/SW/167, and the fastening reassembled.
- 10.3.4 If a guide post has to be renewed then the original holes in the bogie sideplate must be plug welded and the surface re-machined flat and on the same plane as the adjacent guide post surface. All welding must conform to the standards required in BR Specification 528/A. For procedure of locating and securing guide posts see Drg. Nos. E56563, E56540, ES13061 and SC/CW/167.
- 10.3.5 Examine the various components of the damper assembly which locate on the guide post and renew any which are damaged. The 'O' seal, main seal and orifice plate circlip must always be renewed. The following wear tolerances apply:-
- | | |
|-----------------------------|------------|
| Bronze bush O.D. | 5.475" min |
| I.D. | 4.378" max |
| Main seal lower collar I.D. | 4.378" max |
| Main seal upper collar I.D. | 4.631" max |
- The bronze bush may be re-used once only and if re-fitted should be turned 90° from original position and marked accordingly. Alternatively, a Railko bush to Drg. No. C-43-7460 may be used.
- 10.3.6 Examine the internal bore of the outer cylinder and if it is worn greater than 5.507" diameter it must be renewed.
- 10.3.7 Examine the rubber spring. This can be re-fitted provided that any cracks present are not more than 1/16" deep or it is obvious that further deterioration will make it unserviceable before the next bogie repair is due.
- 10.3.8 Examine the dust excluder tube and renew it as necessary. The sealing ring and felt pad must always be renewed. The sealing ring spring should have a free height of $6.3/4 \pm 1/8$ " and a height under a load of 81bf of $3.3/4 \pm 1/8$ ". If not renew.
- 10.3.9 Examine oil filler and plug threads and tube welds, rectify any defects. Renew the Dowty seal.

10.4 Bogie Frame

- 10.4.1 All areas described and drawn in EI G/598 must be examined for fractures. Fractures detected must be rectified as described in Repair Procedure CS/WELD/10. Any notches, flame cut edges, etc., adjacent to those areas must be removed by grinding in accordance with E.I. G/61. Any fractures detected in areas not covered by EIG/598 must be reported immediately to the D of M & EE (BRB) Inter-City Maintenance Section, RTC, Derby.
- 10.4.2 Check for alignment and restore any distortion to drawing dimensions.
- 10.4.3 The bolster control arm spigot must have a uniform taper without wear ridges or corrosion damage and the threads must be clean and free running. Check alignment. Rectify or renew as necessary.
- 10.4.4 Check all fastenings and renew any that are loose.
-
- 10.4.5 Examine all unbushed bolt holes in frame members and brakegear for wear and if greater than the nominal diameter by 1/16" then repair by plug welding and re-drilling. All welding must conform to the standards required in BR Specification 528/A.
- 10.4.6 Examine all bushes and renew any which are loose or with more than 1/64" wear at any position on the nominal internal diameter, excepting those detailed in Appendix "A" which are to be renewed irrespective of condition.
- 10.4.7 Renew alternator (not applicable on Class 307 and 302 EMU bogies) suspension bracket bushes to Drg. No. C-A1-6439/2 (BR Cat No. 52/2129 in Railko WA 82-S material) and adjusting screw bushes to Drg. No. DE/57515/9 (BR Cat No. 18/19217 in Railko AL 11-S material). The bearing surface of the alternator suspension pins to Drg. No. SC/DE/36807/1 (BR Cat No. 18/11190) and adjusting screw pins to Drg. No. DE/57515/2 (BR Cat No. 14/30150) must be checked for wear. Maximum permissible wear 0.020" (0.508 mm) i.e. 0.040" (1.016 mm) on diameter. Items worn to or beyond these limits must be renewed.
- 10.4.8 When the wear of the alternator adjusting screw exceeds the tolerances given in BS 84 it must be replaced with a new adjusting screw as follows:-

<u>Machine</u>	<u>BR Cat No.</u>	<u>Diagram No.</u>
180 amp	14/31930	DE - 57515 Item 3
200 amp	18/8039	SC-DE - 38634 Item 8

Worn bushes to be replaced with new Railko bushes to BR Cat No. 52/2854 Drawing No. 57515.7.

- 10.4.9 Alternator to be overhauled in accordance with WOSS 440/1 (replaces CEPS 46) or WOSS 440/2 (replaces CEPS 47).
- 10.4.10 Following the refitting of the alternator and before fitting the belts, check the pulley alignment in accordance with WOSS 440/4.

10.5 Bolster

- 10.5.1 Examine for flaws, defective welds, etc., and repair.
- 10.5.2 Check for alignment and restore any distortion to drawing dimensions.
- 10.5.3 The control arm spigot must have a uniform taper without wear ridges or corrosion damage and the threads must be clean and free running. Check alignment. Rectify or renew as necessary.
- 10.5.4 Examine bolt holes in bolster for wear and if greater than the nominal diameter by 1/16" then repair by plug welding and re-drilling. All welding must conform to the standards required in BR Specification 528/A.

10.6 Bolster Control Arm

- 10.6.1 Examine for flaws, defective welds, etc., and check alignment. Renew if defective.
- 10.6.2 Renew the rubber bushes, see EI G/281 for details of fitting.

10.7 Brake Block

- 10.7.1 Renew. See MT/191.
- 10.7.2 Examine brake block back and key for flaws and wear and repair or renew as necessary. Check and adjust profile of key to establish a tight hold of brake block in brake block back.

10.8 Brake Disc

- 10.8.1 Examine brake discs in accordance with E.I. G/171. Renew discs if defective or if worn to less than 0.900" thick.

10.9 Brake Gear (Rigging)

- 10.9.1 All brake rigging must be examined for fractures and rubbing marks. Examine pull rods at gusset welds, see Appendix "B". Fractures which can be repaired by welding to be in accordance with the Welding Procedure No. 177-CS(B). Renew all non Beta Nitro Carburised pins and bushes as indicated in Appendix "A". Beta Nitro Carburised treated pins and bushes to be renewed when wear exceeds 1/64".

10.10 Brake Gear Safety Hanger

- 10.10.1 Examine; if rubbing marks caused by interference with brake rigging are present and exceed 1/8" renew. Also check hanger dimensions with those shown on the relevant drawings. Rectify any discrepancies.
- 10.10.2 Examine fixing holes and if worn by more than 1/16" over nominal size repair by plug welding and re-drilling. All welding must conform to the standards required in BR Specification 528/A.

10.11 Lateral Bump Stop

- 10.11.1 Examine rubber for cracking or bonding failure also threaded stud for damage. Renew if defective. Cracks not exceeding 1/16" and bonding failure not exceeding 1/4" are permitted.
 - 10.11.2 Examine hardwood packing and renew if damaged.
-

10.12 Bow Girder

- 10.12.1 Examine the bow girder in accordance with EI HC/614.

10.13 Centre Bearing

- 10.13.1 Examine bottom centre bearing and repair or renew. All welding must conform to the standards required in BR Specification 528/A. Check diameters of centre pin hole and top bearing spigot locating hole and if worn more than 1/16" on nominal diameter renew. If scored on friction pad face deeper than 1/16" build up by welding and restore by machining to drawing dimensions.
- 10.13.2 Examine centre pivot pin and renew if worn by more than 1/16" at any point or if bent.
- 10.13.3 Renew friction pad, if worn in excess of 3/32" and or if heavily impregnated with grease.
- 10.13.4 If the bottom centre bearing is removed from the bolster the felt packing must be renewed.

10.14 Earth Strap

- 10.14.1 Examine and if broken or frayed renew. Ensure that the tab ends are clean and securely attached.

10.15 Friction Damper

- 10.15.1 Dismantle, but leave the link brackets attached to the bogie frame. Clean all components of dirt and rust scale.

- 10.15.2 Examine the link brackets and if they are flawed or otherwise defective or if the friction disc hole is worn more than 1/32" on diameter they must be renewed. If they are of the bushed variety then check the security of the bush in the bracket. See also E.I. HC/89. Should wear extend into the link bracket, machine, and fit oversize bushes.
 - 10.15.3 Examine the link and if flawed or otherwise defective or if maximum wear in width of slot is 1/16" at any one point it must be renewed.
 - 10.15.4 Renew rubber bush.
 - 10.15.5 Examine bottom pin and renew if worn by more than 1/64" at any point.
 - 10.15.6 Renew friction discs.
 - ~~10.15.7 Renew centre pin.~~
 - 10.15.8 Check free height of spring, if less than 3" or if wire is badly corroded the spring must be renewed.
 - 10.15.9 Check that the fitted bolts securing link brackets to bogie frame are tight. If there are any signs of movement the bolt(s) must be removed. If wear has occurred in the link then the hole may be reamed to take a larger diameter bolt, otherwise it must be renewed. If wear has occurred in the bogie frame then the hole may be reamed to take a larger diameter bolt or it may be plug welded and re-drilled.
- 10.16 Hydraulic Dampers
- 10.16.1 All dampers must be tested and overhauled by an approved workshop in accordance with EI's G/56, G/66 and G/188, and lateral dampers in accordance with EI G/59.
- 10.17 Lateral Tie Rod
- 10.17.1 Examine tube and check that the end fittings are parallel and welded on securely. Repair or renew defective items.
 - 10.17.2 Renew bushes and pins worn more than 1/64" on nominal diameter.
- 10.18 Primary and Secondary Coil Springs
- 10.18.1 For the purpose of this document WOSS 616/2 applies. Test as follows:-

SPRING NO.	FREE HEIGHT		TEST LOAD		HEIGHT AT TEST LOAD		COLOUR CODE
	Min	Max	tons	cwt	Min	Max	
CCS 28	11 1/16"	11 9/32"	2	0	7 11/16"	8"	Red
CCS 29	1'2 9/32"	1'2 9/16"	1	16	9 3/32"	9 19/32"	Red
CCS 30	1'0 29/32"	1'1 5/32"	1	10	8 29/32"	9 9/32"	Red
CCS 31	1'3 9/32"	1'3 9/16"	2	4	8 29/32"	9 1/2"	White
CCS 32	10 13/16"	11"	2	8	7 19/32"	7 31/32"	Blue
CCS 33	1'0 5/32"	1'0 13/32"	1	14	9 1/8"	9 13/32"	Blue
CCS 34	1'1 13/32"	1'1 21/32"	3	0	9 1/16"	9 1/2"	Blue
CCS 35	1'3 1/32"	1'3 5/16"	1	4	9"	9 19/32"	Yellow
CCS 36	11 5/16"	11 17/32"	2	16	7 9/16"	8 1/32"	Green
CCS 37	1'0 29/32"	1'1 5/32"	3	10	8 29/32"	8 9/32"	Green
CCS 38	1'1 21/32"	1'1 15/16"	1	9	9"	9 15/32"	Green

Springs are to be fitted to the bogie in accordance with the details shown on the identification plate and given on Drg. No. SC/SW/3397.

10.19 Secondary Suspension Bolt and Rocking Washers

- 10.19.1 Examine bolt for general condition, excessive corrosion and condition of threads. Flaw detect by magnetic particle or dye penetrant methods. Renew as necessary.
- 10.19.2 Examine and gauge rocking washers using gauge H/GA32 and renew those which are worn more than 1/16". To improve clearance between swing rod mounting and the solebar the rocking plate must be machined in accordance with Drg. No. ES/12400/9.
- 10.19.3 Examine split nut for general condition and wear in threads. Renew as necessary.
- 10.19.4 Examine rubber mounting pads. Surface cracking must not exceed a depth of 1/16" and there should be no significant change in hardness.

10.20 Spring Plank

- 10.20.1 Examine for flaws, defective welds, etc., and repair.
- 10.20.2 Check for alignment and rectify any distortion.
- 10.20.3 Examine all bushes and renew any which are loose or with more than 1/64" wear on the nominal internal diameter.

10.21 Spring Plank Safety Loops

- 10.21.1 Examine. If defective repair or renew.
- 10.21.2 Examine fixing holes and if worn by more than 1/16" over nominal size repair by plug welding and re-drilling. All welding must conform to the standards required in BR Specification 528/A.

10.22 Wheels and Axle Including Alternator/Generator Pulley

- 10.22.1 Check wheels for loose tyres and retaining rings and check wheel centres for cracks. Should it be necessary to remove wheels by oil injection method (by authority of the D of M & EE's Quality Assurance Engineer) refer to EI. G/154.
- 10.22.2 Examine axle for scoring, see EI G/360 for reclamation procedure.
- 10.22.3 Check for a bent axle by measuring the wheel back to back dimension in accordance with MT/11 and EI G/497.
- 10.22.4 Check that no movement of wheels or pulley has taken place and ultrasonically test the axle for flaws in accordance with EI G/10 and procedure chart No. 4. The D of M & EE's Quality Assurance Engineer must be informed of any unusual signals found during testing. If a flaw is detected at the axle wheel seat location see EI. G/269 for reclamation procedure. If a flaw is detected at the axle journal shoulder abutment position see EI. HC/258 for remedial action. Examine re-usable/replacement axles in accordance with EI G/498.
-
- 10.22.5 Gauge tyre thickness, tread and flange wear in accordance with MT/11 and EI HC/654 to determine turning or renewal requirements. Minimum tyre thickness after final turning:-
- | | |
|-----------|-------|
| B4 bogies | 35 mm |
| B5 bogies | 38 mm |
- 10.22.6 Remove balance weights from wheel centre. Examine all balance weight retaining bolt holes and take remedial action as necessary in accordance with EI G/11.
- 10.22.7 Replacement tyres must be machined in accordance with EI's G/354 and G/497, and wheel centres must be turned before a new tyre is fitted. See also EI HC/455 and BR Spec No. 164. Minimum permissible wheel centre diameter 782 mm (30.8").
- 10.22.8 Assemble new tyres to wheel centre in accordance with BR Spec No. 164. The interference between wheel centre and tyre must be within the range 0.990 - 1.120 mm.
- 10.22.9 See BR Spec No. 164 for checking dimensions of tyre retaining ring and for procedure when rolling down the tyre lip.

- 10.22.10 Machine the tread to P11 profile, Drg. No. C1-C1-9016365 making reference to booklet MT/11 and EI's G/81 and G/497. Variation of wheel diameters on same axle must not exceed 0.25 mm (0.010"). Accordingly, when a vehicle is reprofiled to P11 profiles at a scheduled maintenance period, and at all subsequent scheduled maintenance periods, ALL brake pins and bushes designated in Appendix A shall be renewed.

Class 307 and 302 EMU bogies. Machine the tread to P1 profile, drg. No. F-C-00172, making reference to MT/11 and EI G/627, G/81, G/497. Variation of Wheel diameter on same axle must not exceed 0.25 mm (0.010").

- 10.22.11 Examine generator flat belt pulley particularly the flanges and renew if defective.
- 10.22.12 Examine alternator vee belt pulley, and gauge for correct profile, renew if defective. Gauge of pulley grooves to be in accordance with C.E.P.S. 47. See also HC/18.
-
- 10.22.13 Check pulley for tightness on axle and repair as necessary.
- 10.22.14 Wheelsets that have been turned and/or overhauled must be dynamically balanced to within the limits stated in BR Specification 164. Secure balance weights, using existing holes where possible, to Drg. No. B-AO-986.
- 10.22.15 Where the axle or wheel centres have been renewed ultrasonically test the axle in accordance with EI G/10 and Procedure Chart No. 4.
- 10.22.16 Protect axle box bearing journals and paint wheelset in accordance with Painting Schedule BR2.
- 10.22.17 Track circuit test must be carried out in accordance with BR Specification 164.
- 10.22.18 WSP Axle Signal Generator to be changed in accordance with WOSS 531/2.
- 10.22.19 WSP Blowdown Valve to be changed in accordance with WOSS 318/1.

11. ASSEMBLY

11.1 General

11.1.1 Only new split pins to be used throughout.

11.2 Secondary Suspension

11.2.1 Reassemble and fit secondary suspension, bolster and centre bearing to bogie frame. Springs must be selected and fitted to Drg. No. SC/SW/3397 and as shown on the identification plate.

11.2.2 Assemble the bolster control arm spigot as follows:-

- (a) Thoroughly clean the tapered surfaces of the spigot and bush.
- (b) Lightly coat the spigot with Esso Rustban 326, BR Cat No. 27/45972.
- (c) With bogie under tare weight tighten nut(s) to 70 Nm to firmly seat bush on spigot.
- (d) Remove nut(s) and check that clearance 'X' (see Data Section) is not less than 1.0 mm.
- (e) Replace nut(s) and tighten to 100 Nm (min). Nut(s) MUST NOT be turned back to fit split pins, further tightening must be applied to achieve the correct alignment.

11.2.3 Lubricate lateral tie rod pins with grease BR Cat No. 27/1350 then fit and secure

11.2.4 When fitting secondary dampers only new or overhauled units may be used.

11.2.5 After fitting bolster bump stops check the 2" clearance dimension shown on the arrangement drawing and adjust if necessary by shimming.

11.3 Wheelsets and Primary Suspension

11.3.1 Remove protection from bearing journals and re-assemble axlebox and bearing to wheelset in accordance with process specification:-

SKF bearings	C.E.P.S. 1002
TIMKEN cartridge bearings	C.E.P.S. 1017
	(B5 PO Vehicles only)

11.3.2 Wheelsets must be fitted to the bogie in matched pairs. Maximum permitted variation in diameter between wheelsets on one bogie is 1/2" and between bogies on one vehicle is 1". Record bogie and wheelset serial numbers.

- 11.3.3 Springs must be selected and fitted to Drg. No. SC/SW/3397 and as shown on the identification plate, and thickness of wood packing according to wheel diameter. Packing must not be re-used.
- 11.3.4 Fill bottom section of dashpot with oil, BR Cat No. 27/12950, to a depth of 3.1/2" and re-assemble.
- 11.3.5 Where hydraulic primary dampers are fitted only new or overhauled units may be used. Friction damper link bracket mounting bolts must be tightened to a torque setting of 200 lbf ft and then the nuts tack welded to the damper link as detailed on the relevant drawing.
- 11.3.6 Alternator belts must be fitted in matched sets of 6. A spare set must also be stored within the pulley drum. (Not applicable on Class 307 and 302 bogie).
- 11.3.7 Fit safety hangers and earth bonding straps. The contact surfaces must be clean and free from paint, rust and scale, and provide good electrical continuity.
-

11.4 Brake Gear (Rigging)

- 11.4.1 Re-assemble brake rigging.
- 11.4.2 Pins must be lubricated during assembly with grease to BR Cat No. 27/1361.
- 11.4.3 When fitting brake blocks check their alignment with wheel tread so that they lie 7/16" - 9/16" inward of the wheel face when hanging freely and that they will wear evenly at the top and bottom. See EI's G/396 and HC/80.

11.5 Bogie Regulation

- 11.5.1 After completion and with the bogie positioned on straight and level track measure the heights and clearances detailed below:-
- (a) Distance from rail to underside of sideplate/headstock gusset plate welded to underside at tare should be 2'1 9/16" \pm 1/8".
 - (b) Combined height of primary spring and packing ring at tare should be 9" \pm 1/8".
 - (c) Clearance between axlebox casting and bump stop on sideplate at tare should be 1 15/16" \pm 1/8".
 - (d) Clearance between bolster and underside of sideplate/headstock gusset plate welded to underside of sideplate at tare should be 7/8" min.
 - (e) Clearance between underframe and bogie side pedestals should be 5/32" min, 11/32" max.

- (f) Clearance between side pedestal and transverse rubber stop on bogie sideplate should be 2".

Rectify any discrepancies.

- 11.5.2 Completed bogie to be painted in accordance with the Painting Schedule BR2. Ensure that all irrelevant, incorrect or superseded stencilling, lettering or labelling is removed.
- 11.5.3 Top up primary dashpots with oil, BR Cat No. 27/12950, to level. The oil level must be within the two 12.5 mm (1/2") markings on the dipstick, the centre of this depth indication is marked 'N' and is 60.5 mm (2.3/8") from the bottom of the inner cylinder. Syringe off oil excess.

Filler plugs to be refitted and correctly tightened to avoid consequential oil leakage.

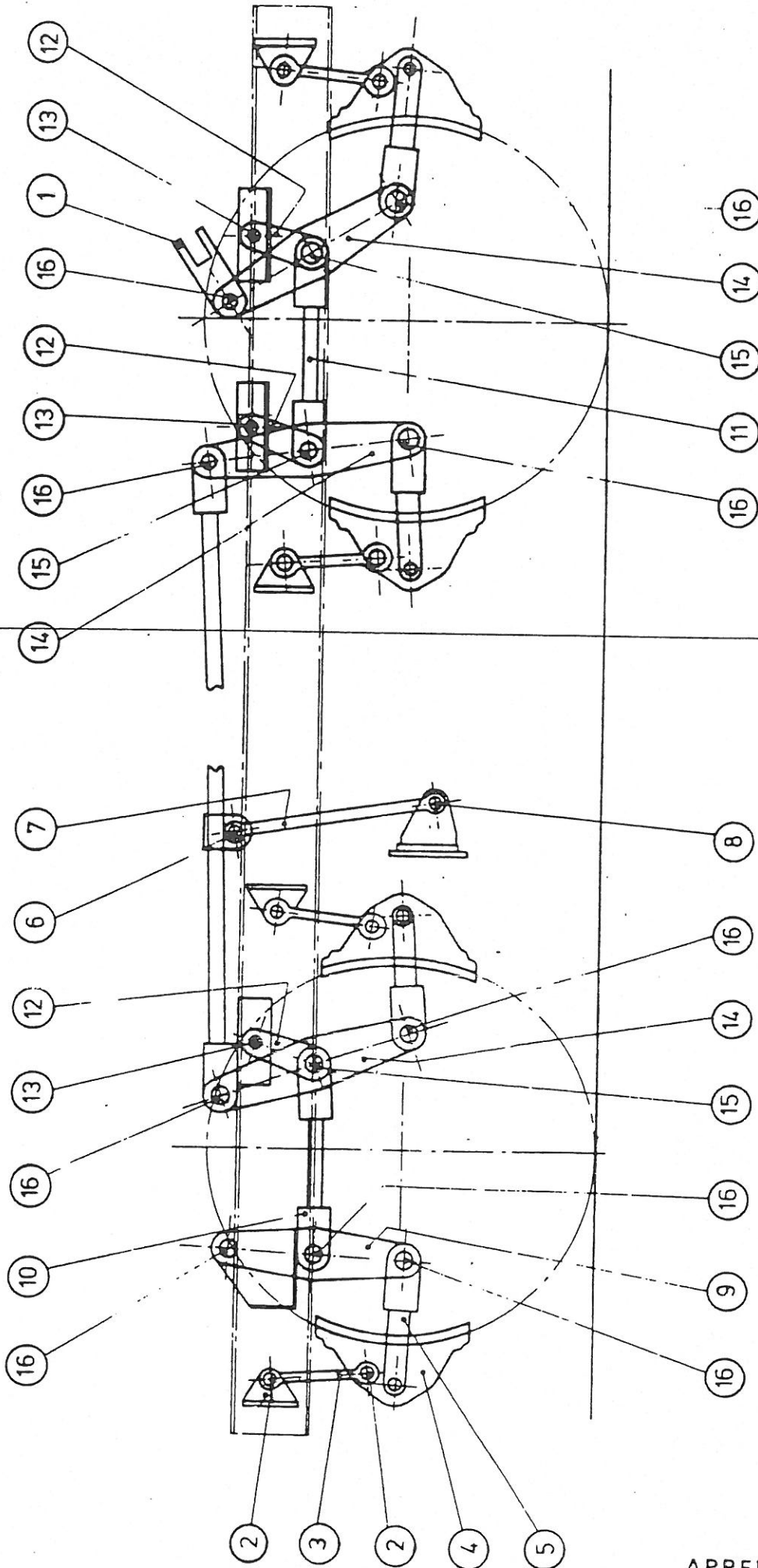

APPENDIX 'A'

<u>ITEM</u>	<u>COMPONENT</u>	<u>PARTS TO BE REPLACED</u>	<u>QUANTITY/BOGIE</u>
1.	Vehicle Pull Rod 7/SC/SW/3167	Bush 15/SC/SW/3167	2
2.		Bolt 10/SC/SW/469	16
3.	Link 15/SC/SW/9	Bush 16/SC/SW/9	16
4.	Brake Block Back 1/SC/SW/2882 Not 100 mph or 3/SC/SW/1011 100 mph	Bush 1/C-A3-2478 Bush 2/C-A3-2478	16 8
5.	Bow Girder 2/SC/SW/3173 or 9000876-01	Bush 3/B-A1-2047 Bush 2/B-A1-2047	4 4
6.		Bolt 13/SC/SW/3167	1
7.	Control Arm 1/SC/SW/3196	Bush 17/SC/SW/3167	2
8.		Bolt 13/SC/SW/3167	1
9.	Lever 2/SC/SW/3167	Bush 14/SC/SW/3167	3
10.	Tie Rod 1/SC/SW/3207	Bush 15/SC/SW/3167	2
11.	Tie Rod 3/SC/SW/3167	Bush 15/SC/SW/3167	4
12.	Small Lever 4/SC/SW/3167 5/SC/SW/3167	Bush 16/SC/SW/3167 Bush 19/SC/SW/3167 Bush 20/SC/SW/3167	6 3 3
13.		Bolt 12/SC/SW/3167	3
14.	Lever 1/SC/SW/3167	Bush 14/SC/SW/3167	9
15.		Bolt 10/SC/SW/3167	3
16.		Bolt 11/SC/SW/3167	9
	Pull Rod		1

All items except 12 and 14 are fitted to B4 Mk IV - VII bogies. Items 12 and 14 are fitted to B4 Mk IV and VII bogies only.

APPENDIX 'B'

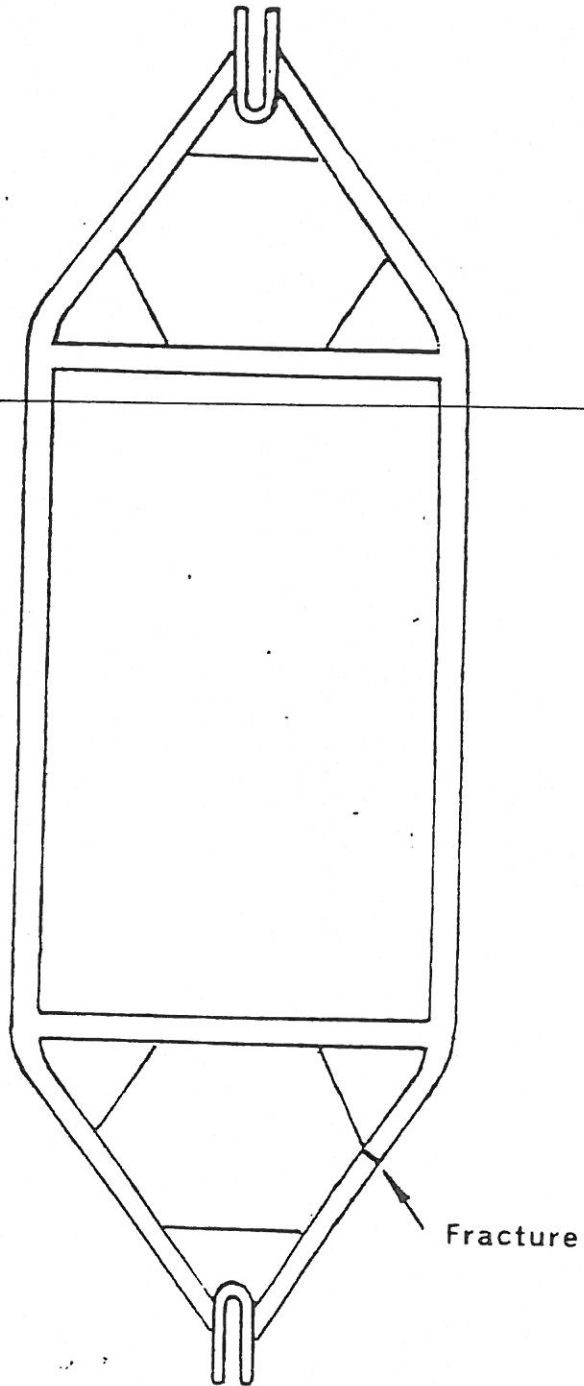

B4 BOGIE DIVIDED PULL ROD

For Training purposes only

A. I.

45 1

THE S.A.B. BRAKE REGULATOR

The slack adjuster is double acting i.e. automatically takes up any excess brake block clearance produced when blocks wear also pays out the required amount if the brake block clearance becomes too small.

The slack adjuster is built into the brake rigging as part of the pull rod.

Unless the gate "A" distance has been interfered with or become altered because of fault in the adjustment, because the brake block clearance is automatically adjusted whether the clearance is too large or too small, there should be no need for manual adjustment in service.

REMOVAL OF BRAKE BLOCKS

In order to get more clearance for fitting new brake blocks, revolve the barrel (19) of slack adjuster clockwise.

After new blocks have been fitted, correct clearance will be automatically restored after a couple of brake applications.

PRINCIPLE OF OPERATION

There are two nuts (1 & 23) on the non - self locking thread of adjuster spindle (41).

The position of nut (1) on the adjuster spindle determines the length of the regulator.

Nut (23) follows the movement of the barrel determined by control rod (45) and barrel spring (21).

Through its grip on the spindle when clutches C & B are locked Nut (23) will be able to pull spindle (41) through nut (1) to lengthen the regulator when there is not enough clearance of blocks or push nut (1) in to shorten the regulator where clearance is too great.

Thus maintaining brake block clearance under control of gate "A". $\frac{5}{8}$ "

THE S.A.B. BRAKE REGULATOR

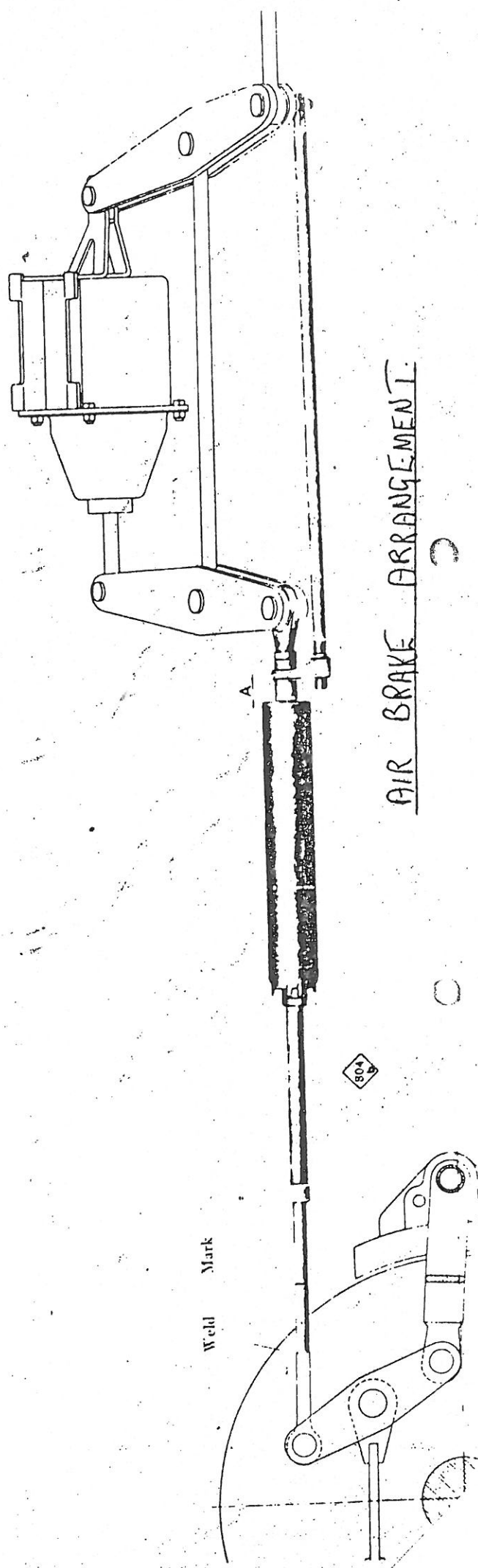
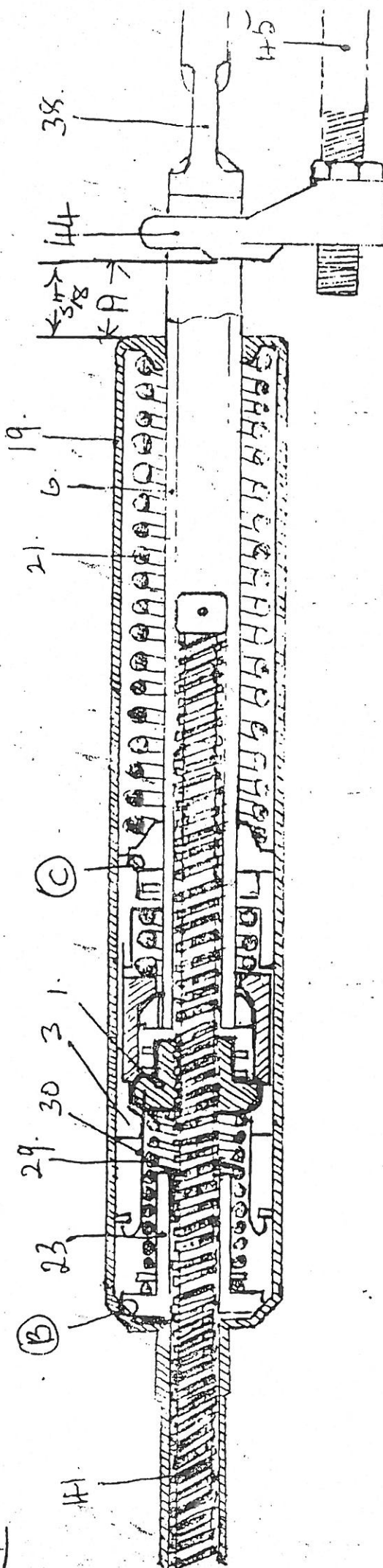

AIR BRAKE ARRANGEMENT

Weld Mark



2
P. 23

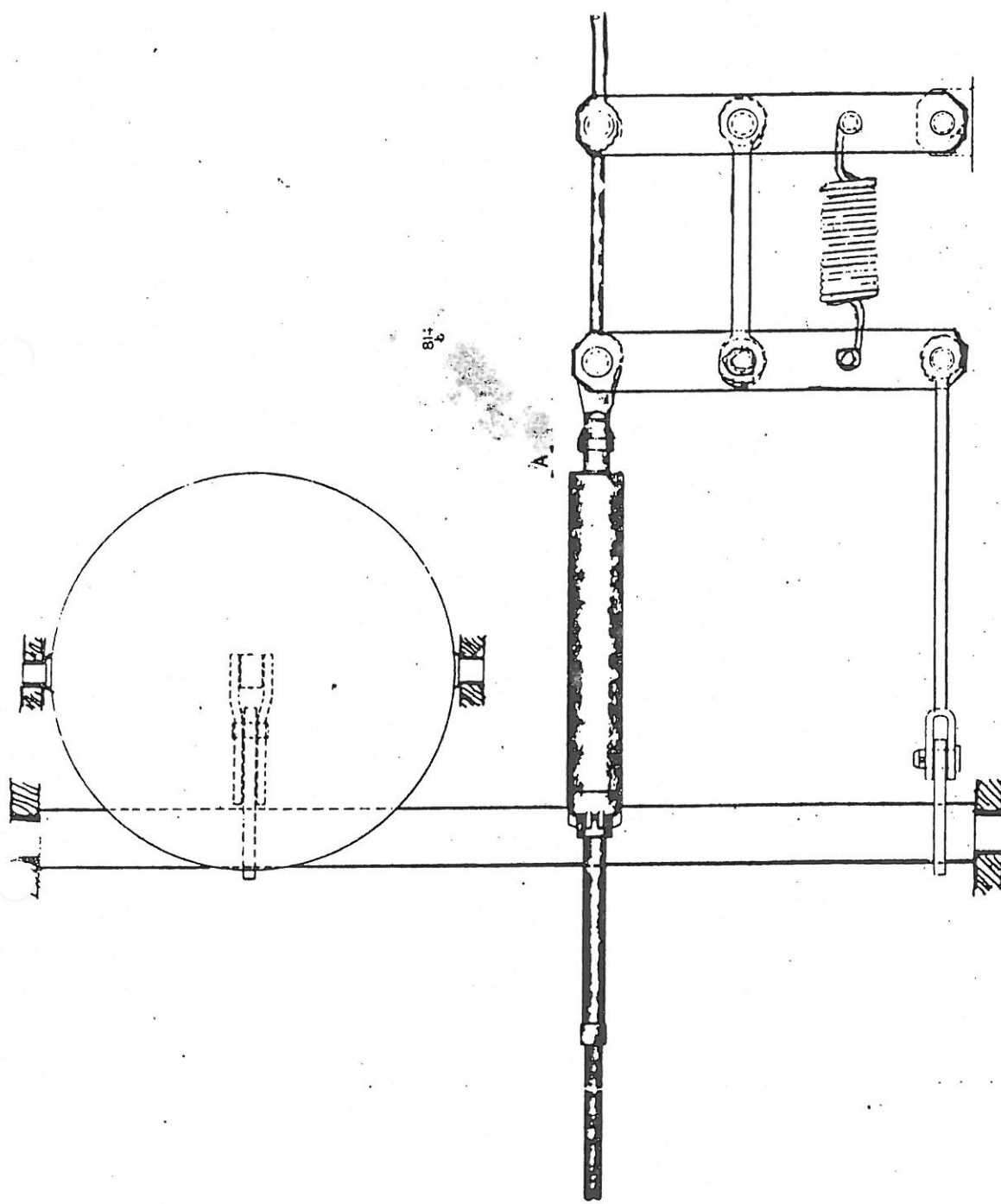

Standard arrangement of SAB Brake Regulator Type DRV for vacuum brake.
 Fig. 2 a.

A. 3.

THE B.R. TYPE B.4. BOGIE

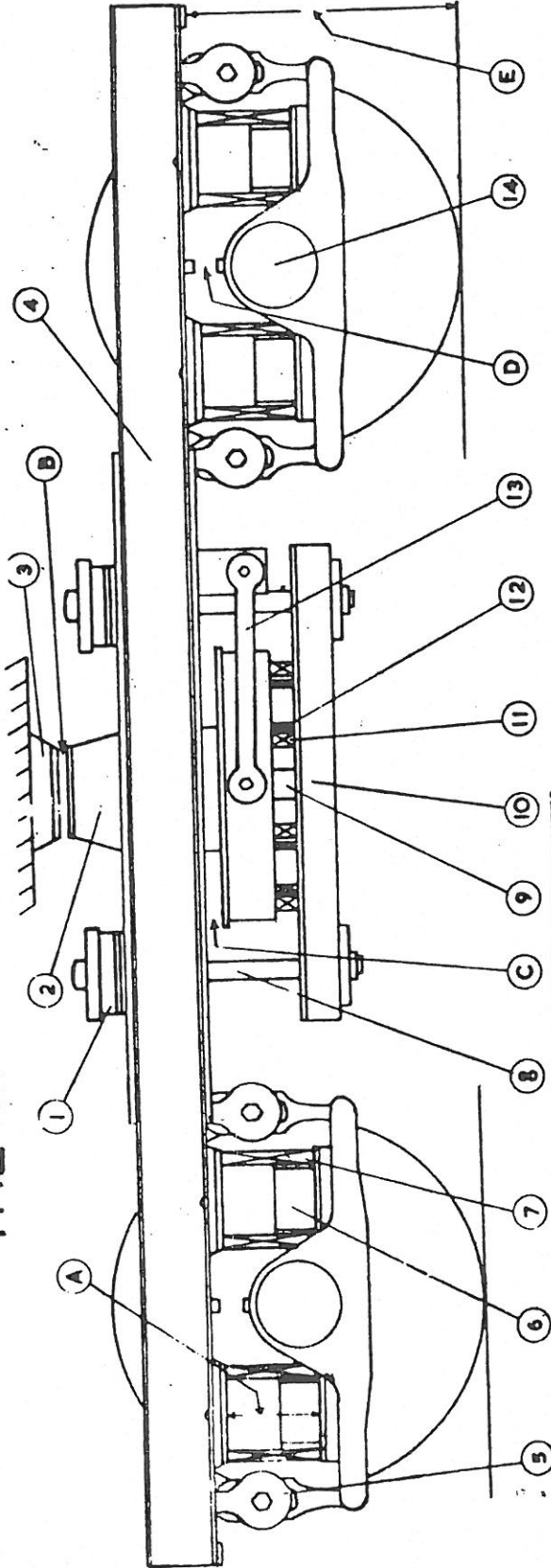

HIGHTS AND CLEARANCES

A. PRIMARY SUSPENSION	MIN. $8\frac{7}{8}$ "	MAX. $9\frac{1}{8}$ "
B. BOLSTER PEDESTAL	MIN. $\frac{5}{32}$ "	MAX. $\frac{11}{32}$ "
C. SIDEPLATE / BOLSTER	MIN. $7\frac{7}{8}$ "	
D. SIDEPLATE / AXLEBOX	MIN. $1\frac{13}{16}$ "	MAX. $2\frac{1}{16}$ "
E. SIDEPLATE HEIGHT	MIN. $2\frac{1}{16}$ "	MAX. $2\frac{11}{16}$ "

DIMENSIONS REFER TO VEHICLES IN THE TAKE CONDITION

1. ROCKING WASHER
2. BOLSTER SIDE PEDESTAL
3. UNDERFRAME SIDE PEDESTAL
4. SIDEPLATE
5. FRICTION DAMPER
6. PRIMARY SUSPENSION DAMPER
7. PRIMARY SUSPENSION SPRING
8. SWING LINK
9. VERTICAL SHOCK ABSORBER
10. SPRING PLANK
11. SECONDARY SPRING (OUTER)
12. SECONDARY SPRING (INNER)
13. BOLSTER CONTROL ARM
14. SCHLIEREN TYPE AXLEBOX

FOR TRAINING PURPOSES ONLY, REFER TO MAKER'S INSTRUCTIONS FOR CURRENT INFORMATION

THE B.R. TYPE B.4. BOGIE
 DIAGRAM NO. C.W.17
 C.M. & E.E. TRAINING SCHOOL
 1/68
 DORCASTER